

# Chapter 8: Friction

# Friction

**Friction** is a force that resists the movement of two contacting surfaces that slide relative to one another. This force acts tangent to the surface at the points of contact and is directed so as to oppose the possible or existing motion between the surfaces.

**Dry Friction (or Coulomb friction)** occurs between the contacting surfaces of bodies when there is no lubricating fluid.



Figure: 08\_COC

The effective design of each brake on this railroad wheel requires that it resist the frictional forces developed between it and the wheel. In this chapter we will study dry friction, and show how to analyze friction forces for various engineering applications.

# Dry friction

- Consider the effects of pulling horizontally (force  $\mathbf{P}$ ) a block of weight  $\mathbf{W}$  which is resting on a **rough** surface.
- The floor exerts an uneven distribution of normal forces  $\Delta\mathbf{N}_n$  and frictional forces  $\Delta\mathbf{F}_n$  along the contacting surface.
- These distributed loads can be represented by their equivalent resultant normal forces  $\mathbf{N}$  and frictional forces  $\mathbf{F}$
- **Equilibrium:** to avoid tipping of the block, the following equilibrium should be satisfied:
- **Impending motion:** the maximum force  $F_s$  before slipping begins is given by

where  $\mu_s$  is called the coefficient of static friction

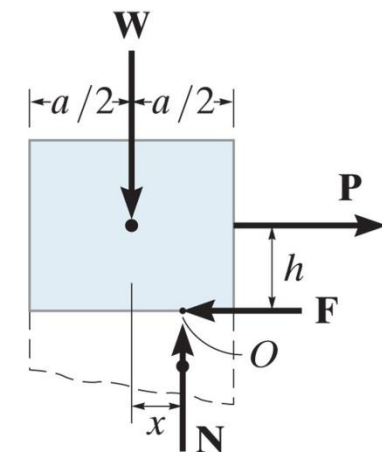
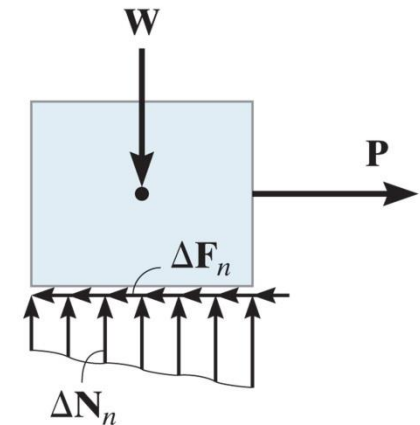
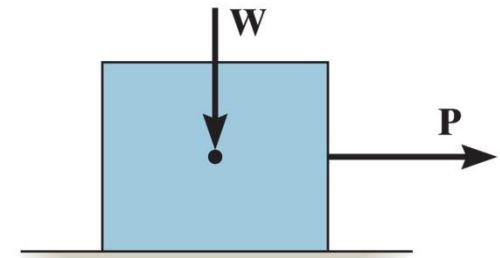

# Dry friction

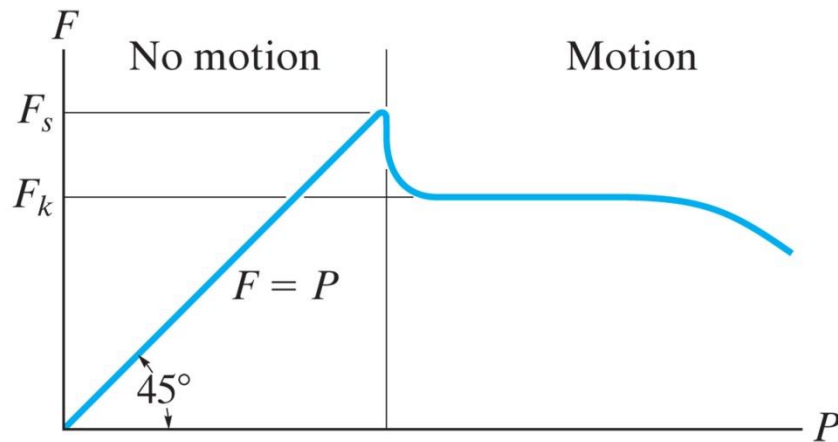
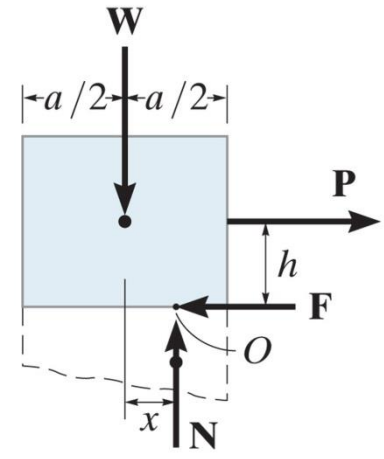
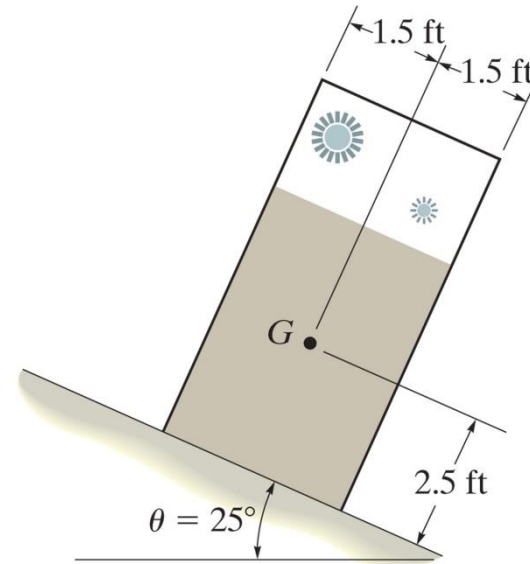
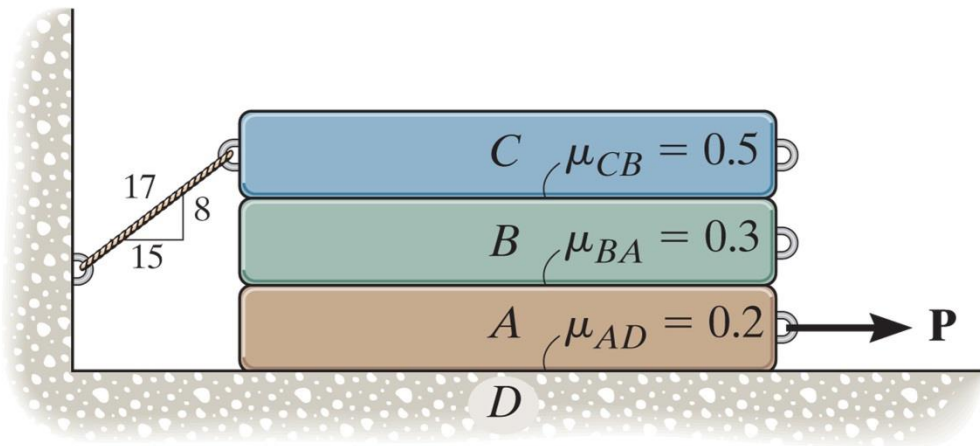

Table 8-1 Typical Values for  $\mu_s$

Contact Materials	Coefficient of Static Friction ( $\mu_s$ )
Metal on ice	0.03–0.05
Wood on wood	0.30–0.70
Leather on wood	0.20–0.50
Leather on metal	0.30–0.60
Aluminum on aluminum	1.10–1.70

It is observed that when the bed of the dump truck is raised to an angle of  $\theta = 25^\circ$  the vending machines will begin to slide off the bed. Determine the static coefficient of friction between a vending machine and the surface of the truck bed.





The three bars have a weight  $W_A = 20$  lb,  $W_B = 40$  lb,  $W_C = 60$  lb respectively. If the coefficient of static friction at the surfaces of contact are as shown, determine the smallest horizontal force  $P$  needed to move block A.

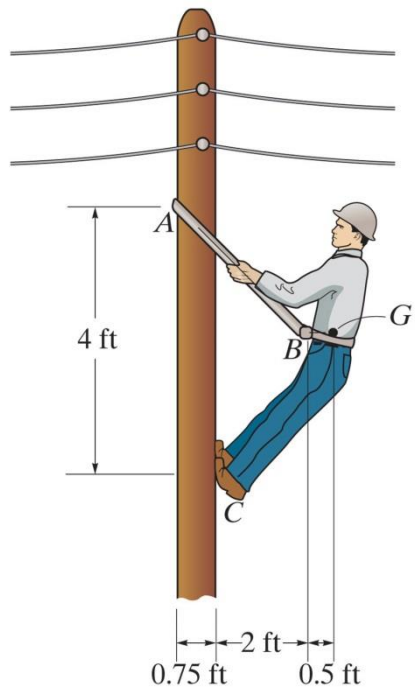

If the coefficient of static friction between the man's shoes and the pole is  $\mu_s = 0.6$ , determine the minimum coefficient of static friction required between the belt and the pole at A in order to support the man. The man has weight of 180 lb and a center of gravity at G.

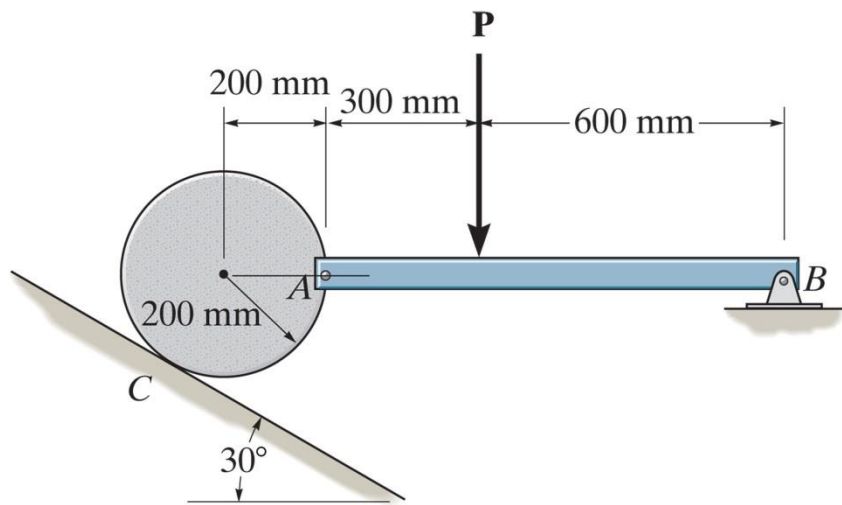

A disk with mass  $M=35$  kg rests on an inclined surface for which  $\mu_s = 0.2$ . Determine the maximum vertical force  $\mathbf{P}$  that can be applied to bar AB without causing the disk to slip at C. Neglect the mass of the bar.



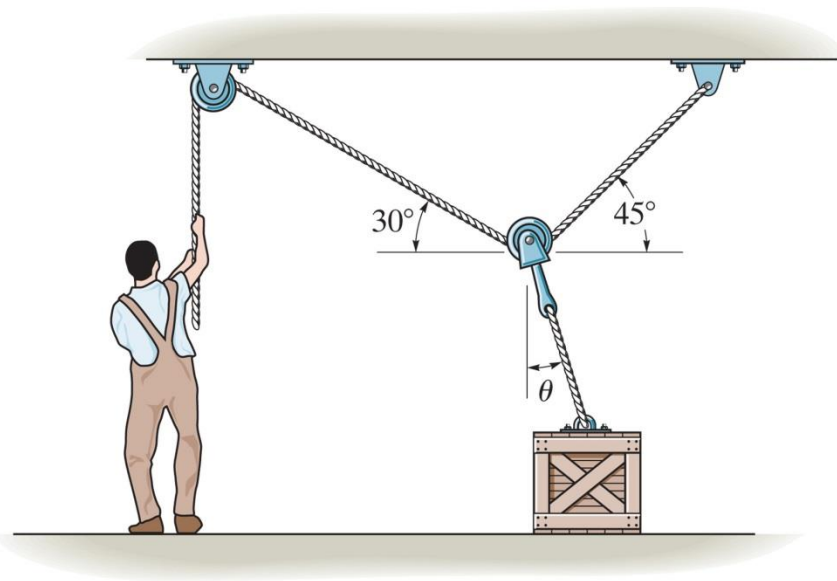

Determine the smallest force the man must exert on the rope in order to move the 80-kg crate. Also, what is the angle  $\theta$  at this moment? The coefficient of static friction between the crate and the floor is  $\mu_s = 0.3$ .